



- **Electronic Housing for Equipment and Devices** -

B 618.0082

The housing B 618.0082 has been designed especially for the installation of electronic devices and for the housing of PCBs and electronic circuits with easy access through clamp brackets. The housing is easily fixed to larger machinery and installation through two bottom holes. Four grommets of SBR rubber aside are opened just on demand for incoming cables.

Technical Data:

Material:	ABS
Ingress protection:	IP6KX-DIN 40050 part 9
Outside dimensions with grommets:	168mm x 106mm x 50mm
Inner physical dimensions:	ca. 130mm x 90mm x 30mm
PCB fixation:	4 x M3x5mm screw threads on 120mm x 76mm
Fixing:	2 x dia5mm in 90mm distance at the bottom

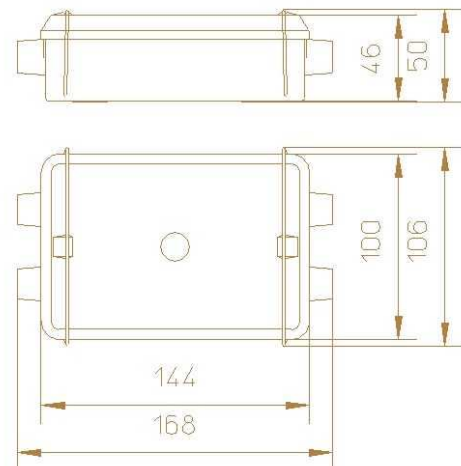
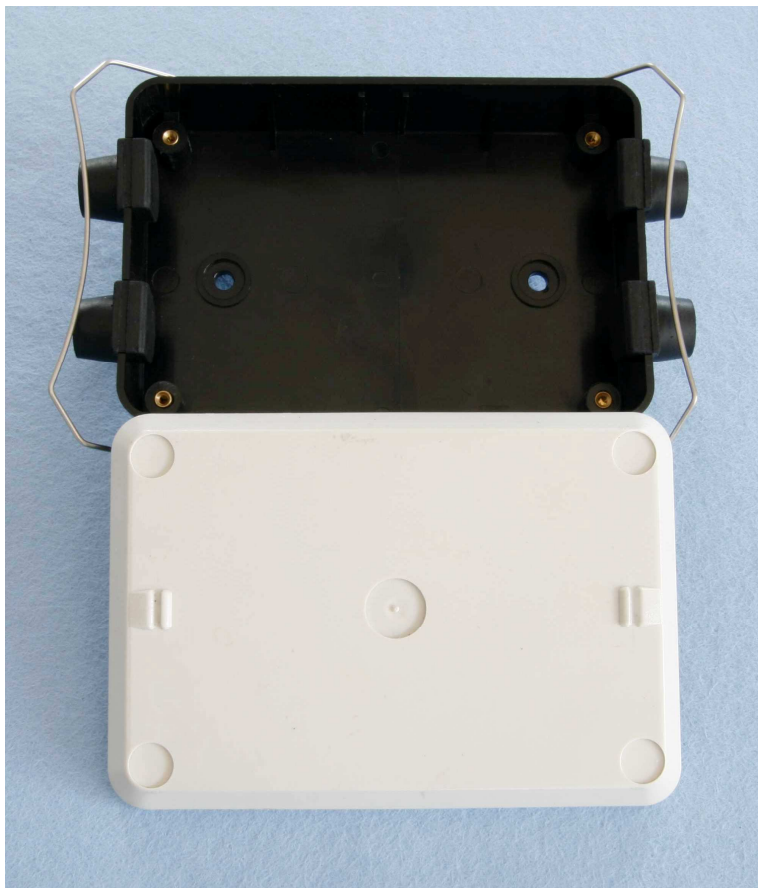

Fig. 1: Opened Housing without PCB

With the part **B 618.0083** we offer a MicroController PCB (as single part B 418.0053) together with the housing, and fixing screws. This package allows to imply a complete μ Controller device with additional electronic components of about 10€ (without display) in a safe and protected environment. Technical data to the PCB B 418.0053 are delivered on demand.